

Inserimento del modulo nella vaschetta.

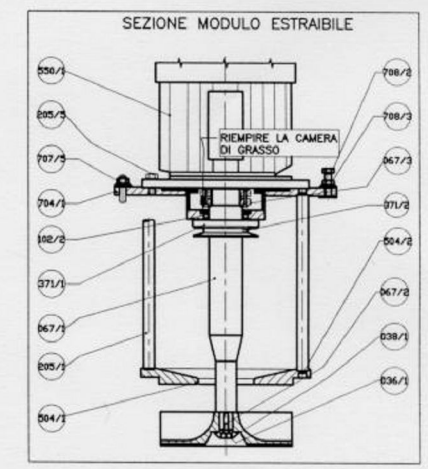
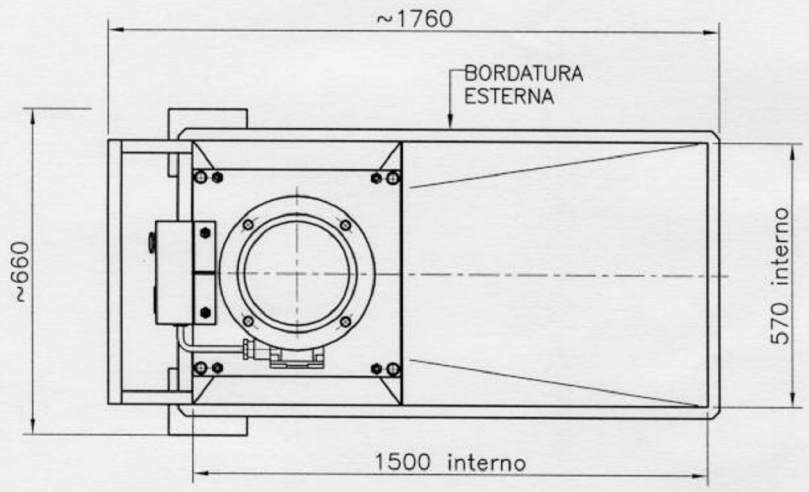
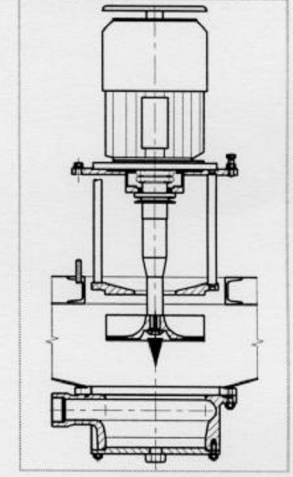

Pos.	Quant.	Denominazione	Materiale	Norm.	Cod.
N10,N11	sgrassato	N7,N8,N9	levigato	N4,N5,N6	rettificato
			Mod.Nr.		
Scala	Rif.	GAD		Sostituito da:	
1:10	Motto:				
Contr. LM			Visto		
ASSIEME POMPA CARRELLATA			TV SOX		
TUTTI I DIRITTI SONO RISERVATI					
Dis.n° SN1115					Rev.

di rugosità	N11	N10	N9	N8	N7	N6	N5	N4
x. μm	25	12,5	6,3	3,2	1,6	0,8	0,4	0,2
di rugosità	▽		▽▽			▽▽▽		
Tolleranze generali dove non indicate \pm (mm)								
Quote mm	da	0	30	120	315	1000	2000	4000
a		30	120	315	1000	2000	4000	8000
/ Fresatura / Foratura		0,1	0,15	0,2	0,3	0,5	0,8	-
anteria / Taglio		1	1,5	2	2	2	2	2

Peso		Pos.mod.	Nr.registro	Nome	Data.
Grezzo	Kg				
		<input type="radio"/> x			
Lavorato	Kg	<input type="radio"/> x			
		<input type="radio"/> x			